



MIRION
TECHNOLOGIES

FoodScreen™ Radiological Food Screening System

Features

- Rapid screening of processed or raw food products for key ¹³¹I, ¹³⁴Cs and ¹³⁷Cs nuclides
- Clear, immediate indication if any nuclide-specific maximum permissible concentrations are exceeded
- Transportable using compact and wheeled detector shield
- Supports wide range of samples including 1 L Marinelli, metal food cans, beverage cans and plastic containers
- Completely battery-powered – from laptop PC's USB port
- Room temperature operation with option for temperature stabilization if measurements will be made out of doors
- Powerful Genie™ 2000 spectroscopy algorithms teamed with the intuitive Genie-FoodPro™ user interface designed specifically for this application
- Turn-key system is provided ready to count, calibrated for typical sample types in a range of common sample containers
- On-site training and/or start-up assistance available from local CANBERRA representative

* NORM - Naturally Occurring Radioactive Material

** US Patent 7,005,646 B1 and 7,049,598 B1

Description

The CANBERRA FoodScreen Radiological Food Screening System is a complete, transportable food analyzer for quickly determining whether raw or processed food has become contaminated from a radiological event. A sample is placed into the shield, a count is initiated and a final report is generated. The report lists activity or minimum detectable activity concentrations found in the sample for the key nuclides of interest for food products: Iodine-131, Cesium-134 and Cesium-137. Based on nuclide-specific limits pre-determined by the system manager, the report will also state whether the sample is "Clean" or "Above Limit". Above limit samples may need to be investigated further in a higher resolution detector system such as the CANBERRA FoodSpec™ Radiological Food Analysis System.

The FoodScreen includes a 2 x 2 in. NaI(Tl) detector (optionally temperature stabilized), 7F7 Mobile FoodScreen Shield, a NORM* KCl calibration check source, Osprey™ Universal Digital MCA Tube Base, industry-standard Genie 2000 spectroscopy algorithms and the Genie-FoodPro application software to streamline and simplify counting operations.

Systems are provided pre-calibrated for a variety of sample types including: water, seawater, dairy products, vegetation, grains, meat, eggs, fish, baby food, etc. Of course, the samples may be raw materials directly from the field or processed foods from a factory, export/import dock, warehouse or retail store. A wide range of sample containers is supported to accommodate both raw and canned foods.

Two different system models are available: FoodScreen and FoodScreen-Plus. The only difference between the two models is the detector. FoodScreen includes a standard 2 x 2 in. NaI(Tl) detector, while FoodScreen-Plus incorporates a patented** NAIS-2x2 LED temperature-stabilized 2 x 2 in. NaI(Tl) detector. Sodium Iodide detectors tend to drift with changes in temperature, causing their spectra to broaden and making the detected nuclides more difficult to identify and quantify. Therefore, FoodScreen-Plus is optimized for use in non-air-conditioned rooms as well as field applications.



FoodScreen Radiological Food Screening System

Simplified Operation – No Compromise on Results

While the spectral acquisition and analysis functions are performed by the same algorithms as used in industry-standard Genie 2000 Spectroscopy Software, the FoodScreen's Genie-FoodPro user interface (Figure 1) is very intuitive with only a few key pieces of information needed to initiate a count: the sample container and the sample contents. Once these items are selected, the user simply clicks the COUNT SAMPLE button to start the acquisition and is presented with a screen to enter the Sample ID and Sample Description. Count time is preset in the system based on the nuclide-specific concentration limits. After the count is complete, a report is generated as in Figure 2 with the activity concentration and a statement as to whether the sample is contaminated or not.

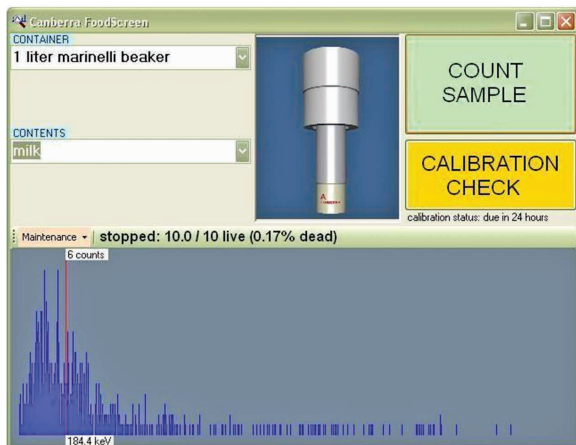

Figure 1.

Sample Container:	1 L Marinelli	
Sample Content:	Milk	
Sample ID:	Milk00001	
Sample Description:	Milk from dairy 2421	
Sample Quantity:	1	
Sample Quantity Units:	Liter	
Measurement started at: 13:40:21 on 11 April 2011		
Counting period: 600 s		
Last calibration check at: 11:28:55 on 10 April 2011		
Activity Concentration Units: Bq/L		
	Activity Concentration	Action Level
Cs-134	6.5	30
Cs-137	7.5	30
I-131	13.2	50
Result: Clean		

Figure 2.

Calibration is just as easy! Genie-FoodPro includes a wide variety of efficiency calibrations for various sample containers and their contents. Only a simple energy

calibration needs to be done to maintain the system – usually daily when in use. The user places the provided Potassium Chloride (KCl) sample on the detector and clicks CALIBRATION CHECK on the computer screen. Then, the system automatically counts for one minute and performs an energy calibration along with any needed adjustments using the naturally-occurring Potassium-40 1462 keV peak. An efficiency check is done as well to verify that the system is ready to process food samples. The calibration and check take only a few minutes, and the results are displayed on the screen and written to a log file. If the test fails, the user is instructed to check the set-up and try again. With calibration complete, the system is ready to count samples until the next calibration check at a frequency determined by the system manager.

Wide Variety of Sample Containers and Types

FoodScreen is designed to handle virtually any food sample that will fit into the 7F7 Shield. As there is an almost infinite number of individual processed and raw food containers that could need to be analyzed, different classes of containers are grouped by size range such that valid comparison of their sample analyses to associated action levels is possible. The purpose is for Genie-FoodPro software to accommodate as many worldwide shapes and sizes of food containers as possible without making an exhaustive list for the user to select from.

The choices include a 1 Liter Marinelli beaker, a number of deli-style plastic containers and a wide variety food and beverage cans as found in food stores.

In general, the quickest counts and best results will come from counting the largest amount of sample possible. The 1 Liter Marinelli beaker shown in the upper left of Figure 3 provides the best possible results because it is one of the largest sample containers that can be used and the detector actually fits up into the bottom of the beaker such that sample surrounds the detector on top and sides. However, the FoodScreen is calibrated for samples as small as a tuna or tomato paste can.



Figure 3.

FoodScreen Radiological Food Screening System

Marinelli Beaker					
				Reference	
1 Liter Marinelli Beaker, 2x2 NaI				GAMA & Assoc. 125G-E	

Food Cans					
Food Can Size	Inches		mm		Example cans
	Diameter Range	Height Range	Diameter Range	Height Range	
1	2.0- 2.1	3.2- 3.6	53.3 - 55.9	81.3 - 91.5	6Z (tomato paste, juice)
2	2.65 - 2.75	3.0 - 4.9	67.3 - 69.9	76.2 - 124.5	No. 1 Picnic (soup, fruit, vegetables)
3	2.9 - 3.1	4.4 - 5.6	73.7 - 78.7	111.8 - 142.2	No. 300 (baked beans, meat products)
4	3.3 - 3.6	4.5 - 5.8	83.8 - 91.5	114.3 - 147.3	No. 2 (soup, juices, fruits)
5	4.0 - 4.3	4.6 - 4.9	101.6 - 109.2	116.8 - 124.9	No. 2.5 (meats, vegetables)
6	4.9 - 5.3	5.4 - 5.8	124.4 - 134.6	137.1 - 147.3	No. 5 (tuna)
7	5.9 - 6.4	4.3 - 4.7	149.9 - 162.6	109.2 - 119.4	Large tuna can
8	2.65 - 2.75	1.4 - 1.8	67.3 - 69.9	35.5 - 45.7	No. 211 (tuna)
9	3.35 - 3.55	1.6 - 2.0	85.1 - 90.2	40.6 - 50.8	No 2 short (tuna)
10	3.9 - 4.2	2.2 - 2.6	99.1 - 106.7	55.9 - 66.0	No. 1.25 (tuna)

Beverage Cans					
Soda/Juice/Energy Drink/Beer Cans	Inches		mm		Example cans
	Diameter Range	Height Range	Diameter Range	Height Range	
Standard: 8 oz / 237 ml - 19.2 oz / 568 ml	2.59 - 2.61	3.4 - 4.7	66.0 - 66.2	88 - 188.1	
Slim/Sleek: : 6.8 oz / 200 ml - 12 oz / 355 ml	1.96 - 2.05	4.3 - 6.2	50 - 52	111.2 - 156.9	

Plastic Containers						
Containers with Lids	Inches			mm		
	Diameter (bottom)	Diameter (top)	Height	Diameter (bottom)	Diameter (top)	Height
8 oz / 237 ml	3.2 - 3.7	4.1 - 4.8	1.6 - 1.9	81.3 - 91.5	104.1 - 121.9	40.6 - 48.3
16 oz / 473 ml	3.2 - 3.7	4.1 - 4.8	2.9 - 3.2	81.3 - 91.5	104.1 - 121.9	73.6 - 81.3
32 oz / 946 ml	3.2 - 3.7	4.1 - 4.8	5.4 - 6.2	81.3 - 91.5	104.1 - 121.9	137.1 - 157.5
V-11 33oz / 975 ml	5.3	5.3	3.0	135	135	76

Figure 4.

Samples can obviously be counted as is, or the contents of smaller ones can be combined into a larger container for faster analysis. The Marinelli and deli-style containers can be used for solid or liquid foods and should be filled to the top. Solids should be packed as tightly as possible to minimize air spaces.

Figure 4 lists the various containers that can be counted by the FoodScreen system. Again, the variations in dimensions of containers from different vendors that are of the same listed volume can typically be accommodated as long as the overall shape is similar.

Typical count times needed to meet minimum detectable activities for specific containers and food types are shown in Figure 5. These examples show the benefit of using a large sample size. The goal of the FoodScreen's design was to provide the lightest and most compact system possible with a count time of 10 minutes or less for larger samples.

Easy Set-up for Non-Experienced Users

While the FoodScreen System is easy to operate, it still needs to be versatile enough to accommodate the various requirements of users throughout the world. After a nuclear power plant radiological event, the three nuclides of most concern to regulatory bodies are Iodine-131, Cesium-134 and Cesium-137. Acceptable limits for these nuclides vary slightly from region to region. Also, limits for baby food are typically more restrictive than for other types of food.

The Genie-FoodPro software is provided with default information that may be usable as is. However, set-up parameters can be modified in its configuration file as needed by CANBERRA representatives or a knowledgeable user with the documentation provided. For quickest deployment, set-up can be done in the factory prior to shipment if required information is provided with the order. Note that a computer (laptop) must either be purchased with the system or provided by the user at time of order for factory set-up.

FoodScreen Radiological Food Screening System

Container (Content)	Cs-137 MDA Target*	Count Time
1 liter Marinelli (Milk or Water)	20 Bq/L	4 mins
Food Can – Size 2** (Vegetables/Meat)	50 Bq/L	8 mins
350 mL Soda Can (Water)	20 Bq/L	110 mins
32 oz Plastic Container (Meat/Fish/Eggs/Grain)	50 Bq/L	20 mins

*typical MDA targets for food screening

**see table of metal food can sizes above

Figure 5.

The following changes can be made to meet regulatory requirements or make operation more efficient for the user. These modifications are usually done only once when initially commissioning the system.

- Change the action levels for ^{131}I , ^{134}Cs and/or ^{137}Cs .
- Change the count time for a sample type.
- Change the activity concentration units (e.g. from mBq/g to $\mu\text{Ci/g}$).
- Change the mass or volume of a sample type.
- Change the generic names of the sample containers to customer-specific names.
- Remove sample containers or food types that are not required (to limit the options on the drop down menus on the main screen).

Higher Resolution System Option

The FoodScreen System is designed for quick screening of food stuffs for the key nuclides of concern after a radiological event. Its size, weight, battery operation and portability allow it to be deployed in the field or wherever the food happens to be.

If more detailed analysis of food is required, particularly of known contaminated food, a higher resolution system employing high purity germanium (HPGe) detectors may be required. Systems such as this are typically installed in laboratories or mobile laboratories due to their size and weight, but they are capable of identifying and quantifying virtually all nuclides in a sample. CANBERRA's FoodSpec Radiological Food Analysis System, described separately, should be considered to meet these more rigorous analysis needs.

Specifications

The FoodScreen Radiological Food Screening System consists of the following products:

- OSPREY Universal Digital MCA Tube Base.
- NAIS-2x2 NaI(Tl) LED Temperature-Stabilized Scintillation Detector (FoodScreen-Plus only).
- 802-2x2 NaI(Tl) Scintillation Detector (FoodScreen only).
- 7F7 Mobile FoodScreen Shield – with KCl Calibration Sample and Laptop Shelf.
- Genie-FoodPro Application Software.

Note: Please see the OSPREY, NAIS-2x2 and 802-2x2 product specification sheets for more detailed information.

OSPREY Universal Digital MCA Tube Base

INPUTS/OUTPUTS

- Standard 14-pin PMT socket and CANBERRA proprietary 8-pin socket.
- USB 2.0.
- Ethernet 10/100T.

POWER

- Main power will be supplied by either the USB port or IEEE 802.3af-compliant Power over Ethernet (PoE).
- Power consumption USB – <2 Watt.
- Power consumption PoE – <3 Watt.

PHYSICAL

- SIZE
 - 62 mm (2.44 in.) diameter.
 - 108 mm (4.25 in.) length.
- WEIGHT – 280 g (9.9 oz).

ENVIRONMENTAL

- TEMPERATURE – -10 to +50 °C (+14 to +122 °F).
- HUMIDITY – 85% non-condensing.
- Meets the environmental conditions specified by EN 61010, Installation Category I, Pollution Degree 2.

FoodScreen Radiological Food Screening System

NAIS-2x2 NaI(Tl) LED Temperature-Stabilized Scintillation Detector

PHYSICAL

- SIZE – See outline drawing. Note that length from crystal cover to Osprey mating surface is 8.9 in. (227 mm).
- WEIGHT – 1 kg (2 lb 4 oz).

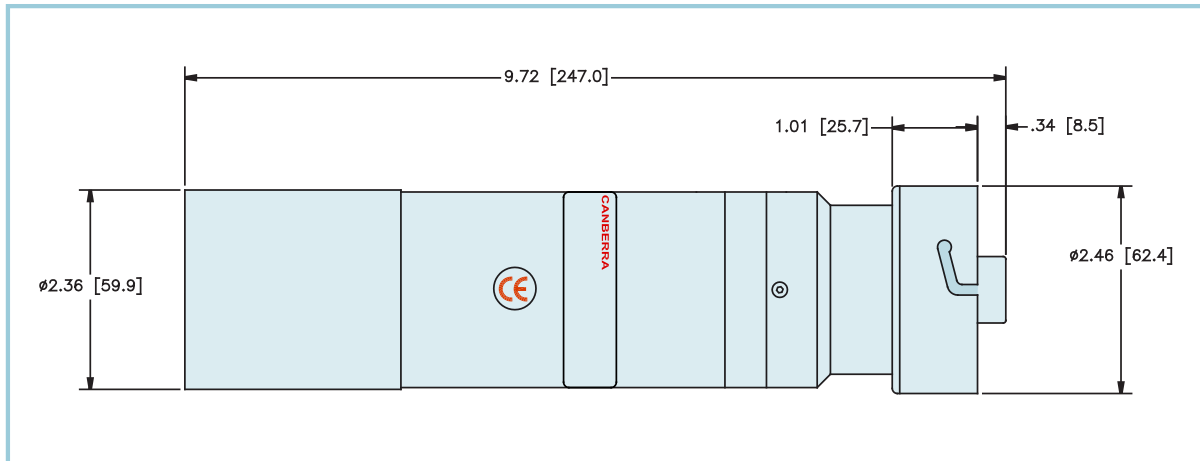

Dimensions in the Outline Drawing are in inches [mm] and are subject to change at the discretion of CANBERRA.

802-2x2 NaI(Tl) Scintillation Detector

PHYSICAL

- SIZE – See outline drawing.
- WEIGHT – 0.77 kg (1 lb 11 oz).

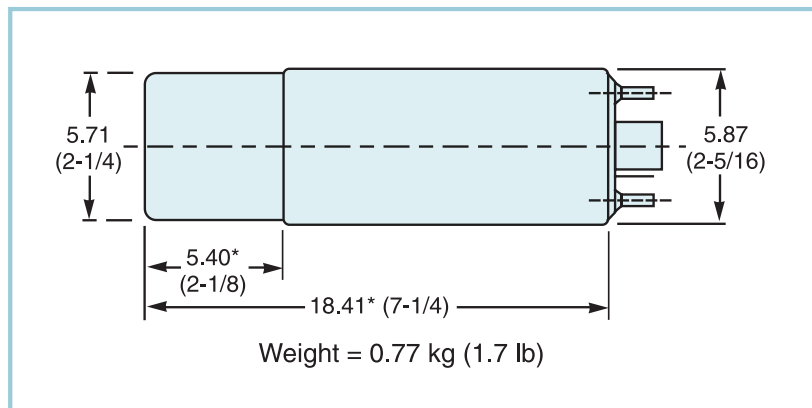

FoodScreen Radiological Food Screening System

7F7 Mobile FoodScreen Shield

MATERIALS

- OUTER JACKET – Cast aluminum alloy – varying thicknesses.
- BULK SHIELD – 3.8-4.2 cm (1.5-1.7 in.) thick low background lead around sample.
- LINING – 2 mm (0.080 in.) 304 stainless steel.

PHYSICAL

- SIZE – See outline drawings (mm).
- WEIGHT – 166 kg (365 lb).
- SHIPPING WEIGHT – 180 kg (395 lb).

FINISH

- CANBERRA light grey textured epoxy.

Genie-FoodPro Application Software

SYSTEM REQUIREMENTS

Genie-FoodPro requires a personal computer with:

- 2.0 GHz Dual Core Pentium® highly recommended.
- 2 GB memory, 200 GB hard disk; CD ROM, USB.
- Integrated 10/100 Ethernet interface.
- 1024 x 768 video adapter.
- Windows® 7 (32-bit) or Windows XP Professional.

ORDERING REFERENCES

- FoodScreen – Radiological Food Screening System with 802-2x2 Detector.
- FoodScreen-Plus – Radiological Food Screening System with NAIS-2x2 Detector.
- Order PC and optional printer separately.
- Order software installation and configuration separately.

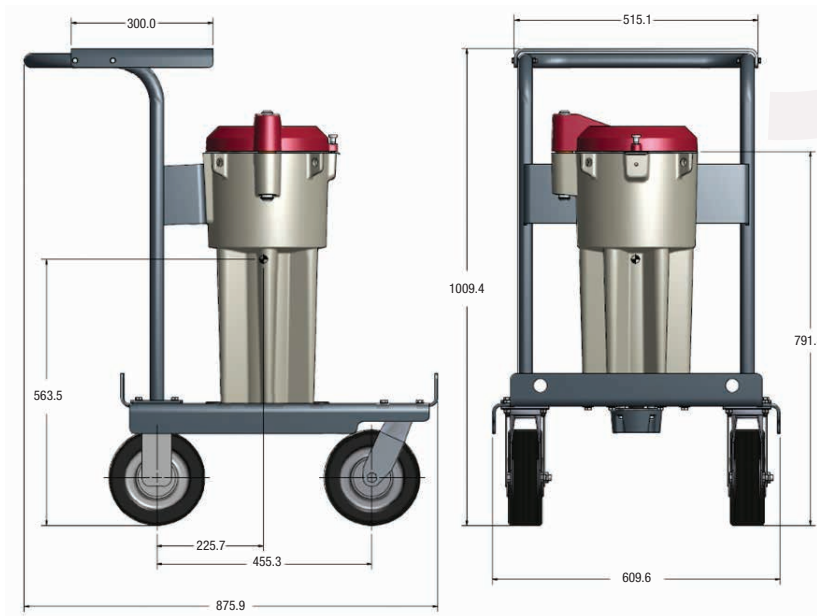
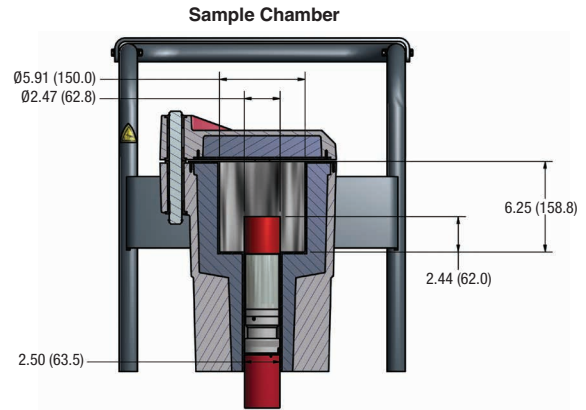

FoodScreen, Genie-FoodPro, Osprey and Genie are trademarks and/or registered trademarks of Mirion Technologies, Inc. and/or its affiliates in the United States and/or other countries.

All other trademarks are the property of their respective owners.

©2017 Mirion Technologies (Canberra), Inc. All rights reserved.

Copyright ©2017 Mirion Technologies, Inc. or its affiliates. All rights reserved. Mirion, the Mirion logo, and other trade names of Mirion products listed herein are registered trademarks or trademarks of Mirion Technologies, Inc. or its affiliates in the United States and other countries. Third party trademarks mentioned are the property of their respective owners.

CANBERRA